



FAIR PRODUCTS



Katalog PRODUKTÓW

PROSPEKT / PRODUCT CATALOGUE

ROZWIĄZANIA DLA PRZEMYSŁU

LÖSUNGEN FÜR DIE INDUSTRIE / SOLUTIONS FOR INDUSTRY

BEZPIECZEŃSTWO ESTETYKA WYGODA

SICHERHEIT ÄSTHETIK KOMFORT / SAFETY AESTHETICS COMFORT



FAIR PRODUCTS

FAIR PRODUCTS

COMPANY AIMS TO CREATE SYSTEMS FOR PEOPLE
AND COMPANIES THAT VALUE BOTH SAFE AND
DURABLE SOLUTIONS



CARDBOARD BOXES COMBINE GOOD LOOKS
WITH CONVENIENCE AND PERFECTLY SECURE OUR
MODULAR GUARD RAILS IN TRANSPORT.

**WE ARE LOOKING FORWARD TO
DOING BUSINESS WITH YOU!**

B0001, B0002, B003

Guard rail with a bar (assembly required)

Guard rail with a bar in RAL 1003 colour is a reliable solution to be used in production and storing premises, designed with protection and safety in mind. Made with durable materials our guard rail boasts exceptional damage resistance. Intensive yellow colour does not only increase the rail's visibility but also contributes to better marking of danger zones or other places requiring extra attention.

Guard rails we offer are perfect for securing machines, walls, posts or fencing off gangways in warehouses, factories and parking lots as well.

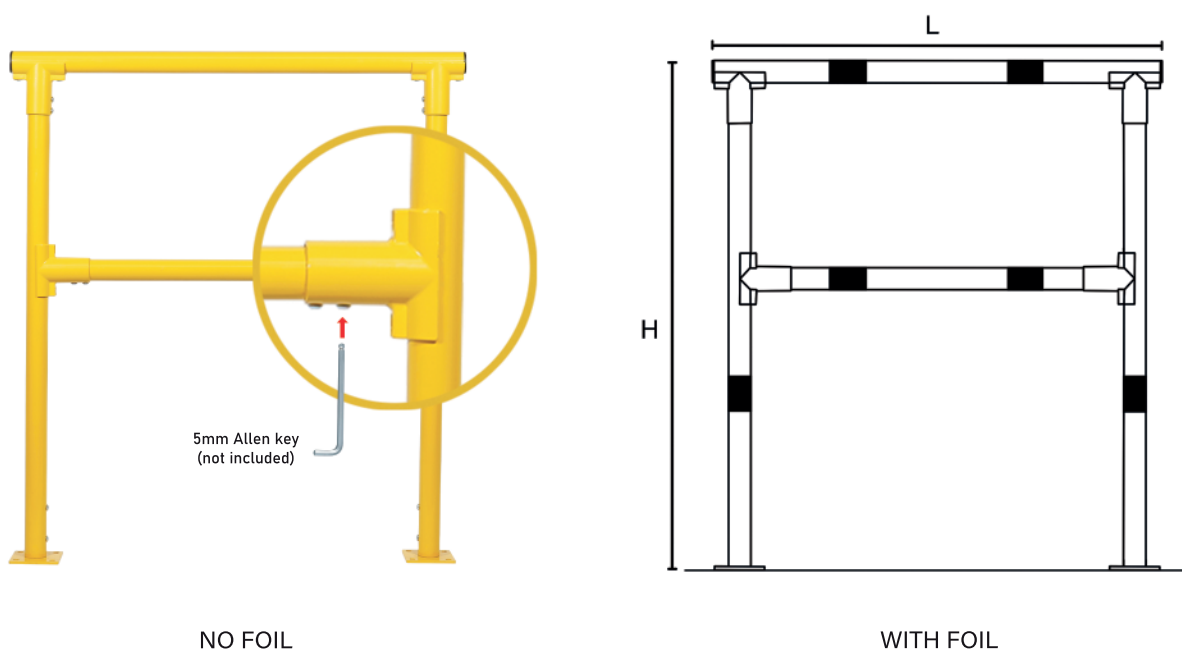

FOIL	DIAMETER	H	L	CATALOGUE NUMBER	PRICE (EAT)	WEIGHT (EAT)
NONE	48,3	110	100	B0001	465 zł	9,9 kg
			150	B0002	525 zł	11,4 kg
			200	B0003	572 zł	12,9 kg
WITH FOIL	48,3	110	100	B0001F	486 zł	9,9 kg
			150	B0002F	553 zł	11,4 kg
			200	B0003F	607 zł	12,9 kg



PRODUCTS SHIPPED IN PACKAGES

B0004, B0005, B0006

Guard rail with a bar and a metal toe board (assembly required)

Guard rail with a bar and a metal toe board is made of high quality materials. It is equipped with a lower metal part which is an additional protection in the area below the knees. Thanks to this solution a guard rail with a metal toe board is perfect for the areas where there is a higher risk for accidents involving employees' lower limbs or of damaging equipment stored on the floor.

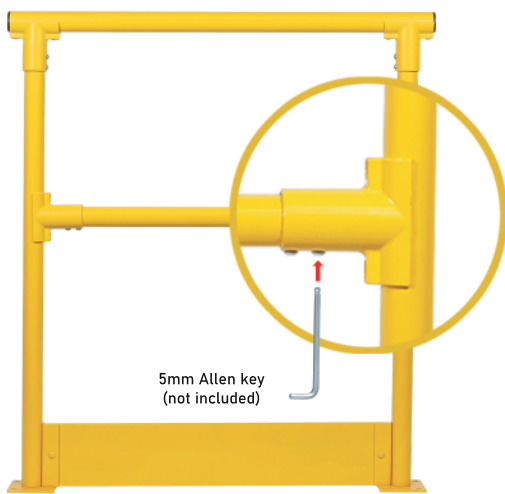

NONE

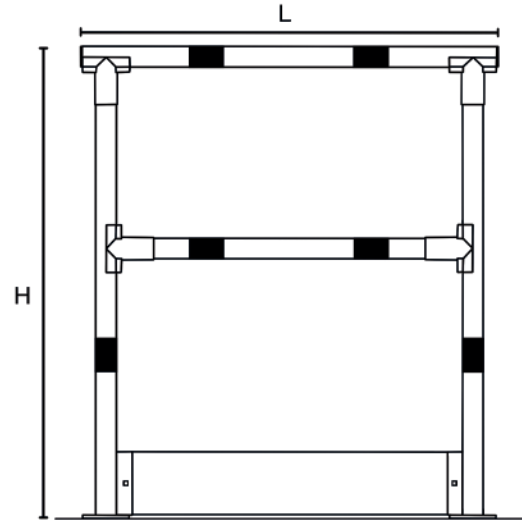

WITH FOIL

FOIL	DIAMETER	H	L	CATALOGUE NUMBER	PRICE (EAT)	WEIGHT (EAT)
NONE	48,3	110	100	B0004	555 zł	13 kg
			150	B0005	640 zł	15,9 kg
			200	B0006	712 zł	26,1 kg
WITH FOIL	48,3	110	100	B0004F	576 zł	13 kg
			150	B0005F	668 zł	15,9 kg
			200	B0006F	747 zł	26,1 kg



PRODUCTS SHIPPED IN PACKAGES

B0014, B0015, B0016,

Metal toe board

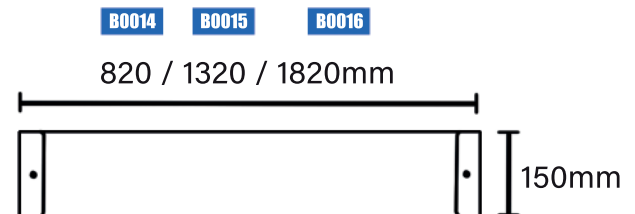

B0007, B0008, B009

Guard rail with a bar and a wooden toe board (assembly required)

Yellow **guard rail with a bar and a wooden toe board** is an esthetic safety solution dedicated for industrial and storing premises. Apart from standard protection against impact it stands out with a unique feature – its lower segment has been equipped with a wooden toe board. Such solution helps protect legs below the knees from impact and also prevents smaller objects from entering protected areas.

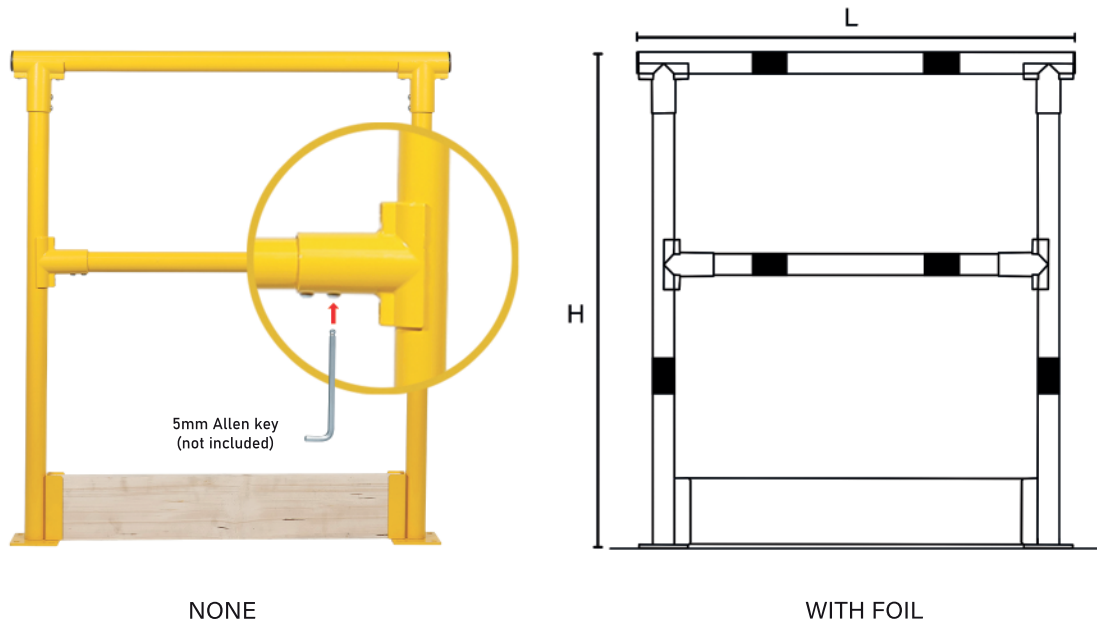

FOIL	DIAMETER	H	L	CATALOGUE NUMBER	PRICE (EAT)	WEIGHT (EAT)
NONE	48,3	110	100	B0007	445 zł	12,9 kg
			150	B0008	621 zł	19,4 kg
			200	B0009	684 zł	25,8 kg
WITH FOIL	48,3	110	100	B0007F	566 zł	12,9 kg
			150	B0008F	649 zł	19,4 kg
			200	B0009F	719 zł	25,8 kg



PRODUCTS SHIPPED IN PACKAGES

B0017, B0018, B0019

Wooden toe board

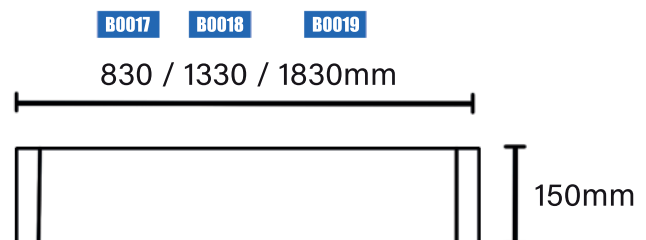

B0010, B0011

Swing gate on a post 80 / 100cm (assembly required)

Swing gate on a post is an ideal solution dedicated for industrial and storing premises. Its primary characteristic is not only functionality and aesthetic looks but also an advanced renowned **Locinox** closing system. This mechanism, mounted in the upper part of the gate, automatically returns to its original position after opening which significantly rises the safety level preventing the gate from being accidentally left open. **Locinox**

closing mechanism guarantees smooth and problem-free use enabling smooth passage, high safety level and effectivity in a dynamic working environment. **Universal design allows the gate to be left- or right-hand mounted.**

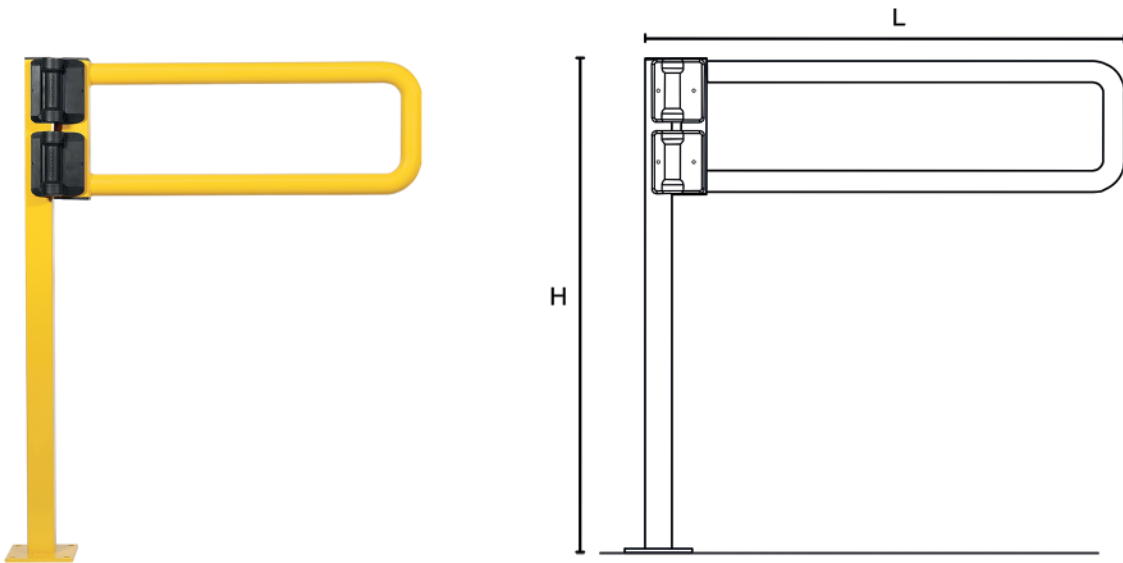

FOIL	POST / DIAMETER	H	L	CATALOGUE NUMBER	PRICE (EAT)	WEIGHT (EAT)
NONE	60x60 / 48,3	110	80	B0010F	1200 zł	9,5 kg
			100	B0011F	1300 zł	11 kg



PRODUCTS SHIPPED IN PACKAGES

B0012, B0013

Double-post swing gate (assembly required)

Double-post swing gate is an ideal solution dedicated for industrial and storing premises. Its primary characteristic is not only functionality and aesthetic looks but also an advanced renowned **Locinox** closing system. This mechanism, mounted in the upper part of the gate, automatically returns to its original position after opening which significantly rises the safety level preventing the gate from being accidentally left open. **Locinox** closing mechanism guarantees smooth and problem-free use enabling smooth passage, high safety level and effectivity in a dynamic working environment. **Universal design allows the gate to be left- or right-hand mounted.**

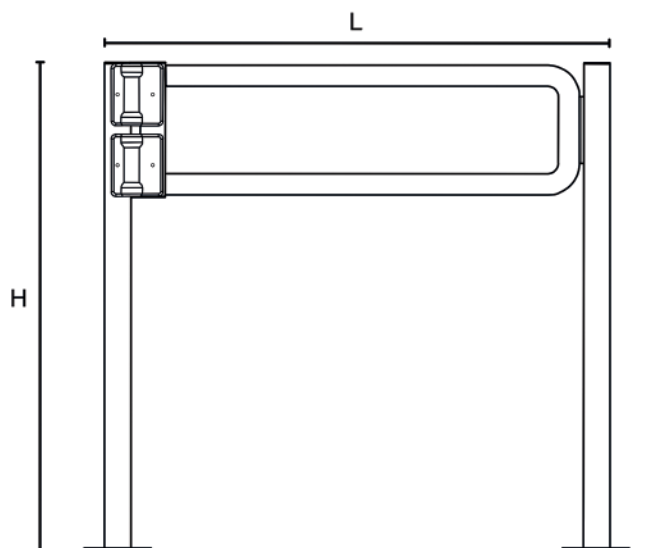

FOIL	POST / DIAMETER	H	L	CATALOGUE NUMBER	PRICE (EAT)	WEIGHT (EAT)
NONE	60x60 / 48,3	110	80	B0012F	1400 zł	14,9 kg
			100	B0013F	1500 zł	16,4 kg



PRODUCTS SHIPPED IN PACKAGES

CONNECTING ELEMENTS FOR WOODEN AND METAL TOE BOARDS

B0020

Wooden toe board holder



B0021, B0022, B0023

Frontal C / H / T pole bumper

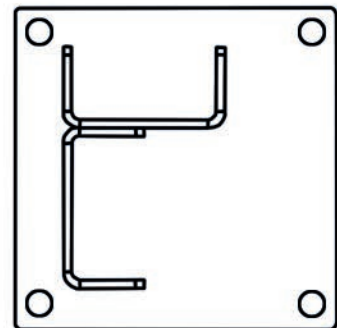
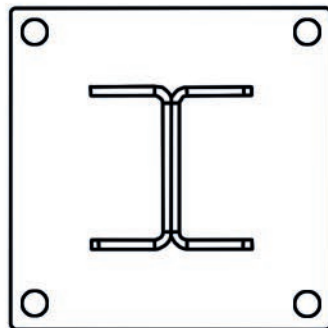
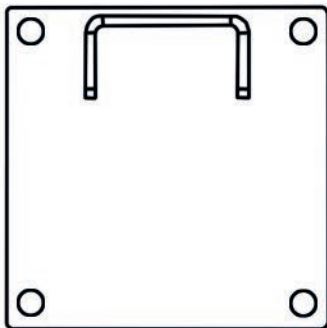

GUARDS AND BUFFERS

RC00005s

Frontal pole bumper

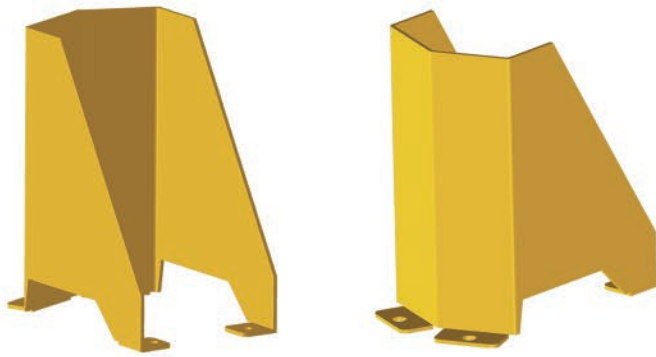

AVAILABLE ON
REQUEST

ORU20052

Bumper barrier U2

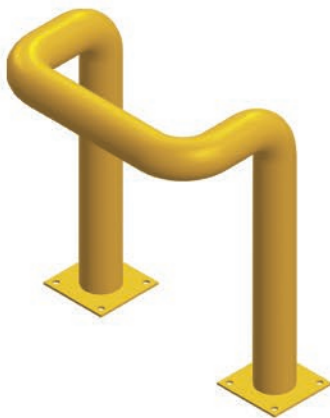

AVAILABLE ON
REQUEST

ORP010A

Barless single bumper barrier



AVAILABLE ON
REQUEST



FAIR PRODUCTS

All dimensions are informative and may vary slightly from the actual dimensions, in accordance with Art. 66 § 1 of the Civil Code

The specified prices are net prices expressed in PLN and currently applicable VAT should be added to them in rate A (as of 1.01.2024, that is 23%). Catalog prices of products are subject to change. Price list in accordance with art. 71 of the Civil Code does not constitute an offer, but an invitation to conclude a contract for the sale of products at the price indicated in the individual offer.

www.fair-products.com

A long, light-colored wooden barrier is shown in a factory setting. The barrier is supported by yellow metal brackets at the ends and by yellow metal connectors along its length. The background shows industrial equipment and a concrete floor.

Elementy łączące do zapór drewnianych i metalowych

Connecting elements
for wooden and metal barriers

Verbindungselemente
für Metall- und Holzbarriere

Odbojnice rurowe

Tubular protectors

Schutzgeländer





FAIR PRODUCTS

Fair Products Sp. z o.o.
ul. Robotnicza 5
58-100 Świdnica, Polska



+48 730 630135



biuro@fair-products.com